

AXOR®

hansgrohe

DE	Gebrauchsanleitung / Montageanleitung	2
FR	Mode d'emploi / Instructions de montage	2
EN	Instructions for use / assembly instructions	3
IT	Istruzioni per l'uso / Istruzioni per Installazione	3
ES	Modo de empleo / Instrucciones de montaje	4
NL	Gebruiksaanwijzing / Handleiding	4
DK	Brugsanvisning / Monteringsvejledning	5
PT	Instruções para uso / Manual de Instalação	5
PL	Instrukcja obsługi / Instrukcja montażu	6
CS	Návod k použití / Montážní návod	6
SK	Návod na použitie / Montážny návod	7
ZH	用户手册 / 组装说明	7
RU	Руководство пользователя / Инструкция по монтажу	8
HU	Használati útmutató / Szerelési útmutató	8
FI	Käyttöohje / Asennusohje	9
SV	Brugsanvisning / Monteringsanvisning	9
LT	Vartotojo instrukcija / Montavimo instrukcijos	10
HR	Upute za uporabu / Uputstva za instalaciju	10
TR	Kullanım kılavuzu / Montaj kılavuzu	11
RO	Manual de utilizare / Instrucțiuni de montare	11
EL	Οδηγίες χρήσης / Οδηγία συναρμολόγησης	12
SL	Navodilo za uporabo / Navodila za montažo	12
ET	Kasutusjuhend / Paigaldusjuhend	13
LV	Lietošanas pamācība / Montāžas instrukcija	13
SR	Uputstvo za upotrebu / Uputstvo za montažu	14
NO	Brugsanvisning / Montasjeveiledning	14
BG	Инструкция за употреба / Ръководство за монтаж	15
SQ	Udhëzuesi i përdorimit / Udhëzime rreth montimit	15
AR	دليل الاستخدام / تعليمات التجميع	16

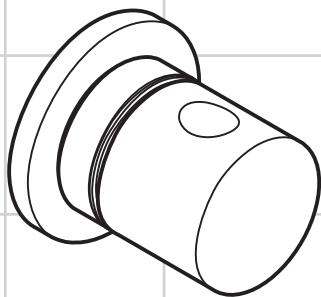

Uno 2
38976000



Sicherheitshinweise

- ⚠ Bei der Montage müssen zur Vermeidung von Quetsch- und Schnittverletzungen Handschuhe getragen werden.

Montagehinweise

- Die Armatur muss nach den gültigen Normen montiert, gespült und geprüft werden!
- Vor der Montage muss das Produkt auf Transportschäden untersucht werden. Nach dem Einbau werden keine Transport- oder Oberflächenschäden anerkannt.

Symbolerklärung



Kein essigsäurehaltiges Silikon verwenden!



Maße (siehe Seite 18)



Serviceteile (siehe Seite 18)



Reinigung

Reinigungsempfehlung siehe beiliegende Broschüre.



Prüfzeichen (siehe Seite 20)

Consignes de sécurité

- ⚠ Lors du montage, porter des gants de protection pour éviter toute blessure par écrasement ou coupure.

Instructions pour le montage

- La robinetterie doit être installée, rincée et contrôlée conformément aux normes valables!
- Avant son montage, s'assurer que le produit n'a subi aucun dommage pendant le transport. Après le montage, tout dommage de transport ou de surface ne pourra pas être reconnu.

Description du symbole



Ne pas utiliser de silicone contenant de l'acide acétique!



Dimensions (voir page 18)



Pièces détachées (voir pages 18)



Nettoyage

Pour les conseils d'entretien, voir la brochure ci-jointe.



Classification acoustique et débit (voir page 20)





Safety Notes

-  Gloves should be worn during installation to prevent crushing and cutting injuries.

Installation Instructions

- The fitting must be installed, flushed and tested after the valid norms!
- Prior to installation, inspect the product for transport damages. After it has been installed, no transport or surface damage will be honoured.

Symbol description



Do not use silicone containing acetic acid!



Dimensions (see page 18)



Spare parts (see page 18)



Cleaning

Cleaning recommendations, see enclosed brochure.



Test certificate (see page 20)

Indicazioni sulla sicurezza

-  Durante il montaggio, per evitare ferite da schiacciamento e da taglio bisogna indossare guanti protettivi.

Istruzioni per il montaggio

- La rubinetteria deve essere installata, pulita e testata secondo le istruzioni riportate!
- Prima del montaggio è necessario controllare che non ci siano stati danni durante il trasporto. Una volta eseguito il montaggio, non verranno riconosciuti eventuali danni di trasporto o delle superfici.

Descrizione simbolo



Non utilizzare silicone contenente acido acetico!



Ingombri (vedi pagg. 18)



Parti di ricambio (vedi pagg. 18)



Pulitura

Suggerimenti per la pulizia: vedi il prospetto accluso.



Segno di verifica (vedi pagg. 20)

Assembly
see page 17



Montaggio
vedi pagg. 17



Indicaciones de seguridad

- ⚠ Durante el montaje deben utilizarse guantes para evitar heridas por aplastamiento o corte.

Indicaciones para el montaje

- El grifo tiene que ser instalado, probado y testado, según las normas en vigor.
- Antes del montaje se debe examinarse el producto contra daños de transporte. Después de la instalación so se reconoce ningún daño de transporte o de superficie.

Descripción de símbolos



No utilizar silicona que contiene ácido acético!



Dimensiones (ver página 18)



Repuestos (ver página 18)



Limpiar

Para las instrucciones de limpieza, ver el folleto adjunto.



Marca de verificación (ver página 20)

Veiligheidsinstructies

- ⚠ Bij de montage moeten ter voorkoming van kniel- en snijwonden handschoenen worden gedragen.

Montage-instructies

- Leidingen doorspoelen volgens Norm. De mengkraan vervolgens monteren en controleren!
- Vóór de montage moet het product gecontroleerd worden op transportschade. Na de inbouw wordt geen transport- of oppervlakteschade meer aanvaard.

Symbolbeschrijving



Gebruik geen zuurhoudende silicone!



Maten (zie blz. 18)



Service onderdelen (zie blz. 18)



Reinigen

Reinigingsadvies zie bijgevoegde brochure.



Keurmerk (zie blz. 20)





Sikkerhedsanvisninger

- ⚠ Ved monteringen skal der bruges handsker for at undgå kvæstelser og snitsår.

Monteringsanvisninger

- Ifølge gældende regler, skal armaturet monteres, skylles igennem og afprøves.
- Før monteringen skal produktet kontrolleres for transportskader. Efter monteringen godkendes transportskader eller skader på overfladen ikke længere.

Symbolbeskrivelse



Der må ikke benyttes eddikesyreholdig silikone!



Målene (se s. 18)



Reserve dele (se s. 18)



Rengøring

For anbefalinger til rengøringen, se venligst den vedlagte brochure.



Godkendelse (se s. 20)

Avisos de segurança

- ⚠ Durante a montagem devem ser utilizadas luvas de protecção, de modo a evitar ferimentos resultantes de entalamentos e de cortes.

Avisos de montagem

- A misturadora deve ser instalada, purgada e testada de acordo com as normas em vigor!
- Antes da montagem deve-se controlar o produto relativamente a danos de transporte. Após a montagem não são aceites quaisquer danos de transporte ou de superfície.

Descrição do símbolo



Não utilizar silicone que contenha ácido acético!



Medidas (ver página 18)



Peças de substituição (ver página 18)



Limpeza

Consultar a seguinte brochura sobre as recomendações de limpeza.



Marca de controlo (ver página 20)





Wskazówki bezpieczeństwa

- ⚠ Aby uniknąć zranień, takich jak zgniecenia czy przecięcia, podczas montażu należy nosić rękawice.

Wskazówki montażowe

- Armatura musi być zamontowana, przepukana i wypróbowana według obowiązujących norm!
- Przed montażem należy skontrolować produkt pod kątem szkód transportowych. Po montażu nie widać żadnych szkód transportowych ani szkód na powierzchni.

Opis symbolu



Nie stosować silikonów zawierających kwas octowy!



Wymiary (patrz strona 18)



Części serwisowe (patrz strona 18)



Czyszczenie

Zalecenie dotyczące pielęgnacji, patrz dołączona broszura.



Znak jakości (patrz strona 20)

Bezpečnostní pokyny

- ⚠ Pro zabránění řezným zraněním a pohmožděním je nutné při montáži nosit rukavice.

Pokyny k montáži

- Armatura se musí montovat, proplachovat a testovat podle platných norem!
- Před montáží je třeba produkt zkontrolovat, zda nebyl při transportu poškozen. Po zabudování nebudou uznány žádné škody způsobené transportem nebo poškození povrchu.

Popis symbolů



Nepoužívat silikon s obsahem kyseliny octové!



Rozměry (viz strana 18)



Servisní díly (viz strana 18)



Čištění

Doporučení k čištění viz přiložená brožura.



Zkušební značka (viz strana 20)





Bezpečnostné pokyny

-  Pri montáži musíte nosiť rukavice, aby ste predišli pomliaždeninám a rezným poraneniam.

Pokyny pre montáž

- Batéria sa musí montovať, preplachovať a testovať podľa platných noriem!
- Pred montážou musíte produkt skontrolovať, či nebol počas transportu poškodený. Po zabudovaní nebudú uznané žiadne škody spôsobené transportom alebo poškodenia povrchu.

Popis symbolov



Nepoužívať silikón s obsahom kyseliny octovej!



Rozmery (viď strana 18)



Servisné diely (viď strana 18)



Čistenie

Odporúčanie o čistení nájdete v priloženej brožúre.



Osvedčenie o skúške (viď strana 20)

安全技巧

-  装配时为避免挤压和切割受伤，必须戴上手套。

安装提示

- 必须按照现行的规定安装，冲洗和测试产品！
- 安装前必须检查产品是否受到运输损害。安装后将不认可运输损害或表面损伤。

符号说明



请勿使用含有乙酸的硅！



大小 (参见第 18 页)



备用零件 (参见第 18 页)



清洗

清洁建议参见附入的小册子。



检验标记 (参见第 20 页)





Указания по технике безопасности

- ⚠ Во время монтажа следует надеть перчатки во избежание прищемления и порезов.

Указания по монтажу

- Смеситель должен быть смонтирован по действующим нормам и в соответствии с настоящей инструкцией, проверен на герметичность и безупречность работы
- Перед монтажом следует проверить изделие на предмет повреждений при перевозке. После монтажа претензии о возмещении ущерба за повреждения при перевозке или повреждения поверхностей не принимаются.

Описание символов



Не применяйте силикон, содержащий уксусную кислоту.



Размеры (см. стр. 18)



Комплект (см. стр. 18)



Очистка

Рекомендации по очистке см. в прилагаемой брошюре.



Знак технического контроля (см. стр. 20)



Biztonsági utasítások

- ⚠ A szerelésnél a zúzódások és vágási sérülések elkerülése érdekében kesztyűt kell viselni.

Szerelési utasítások

- A csaptelepet az érvényben lévő előírásoknak megfelelően kell felszerelni, átöblíteni és ellenőrizni!
- A szerelés előtt ellenőrizni kell, hogy a terméknek nincs-e szállítási sérülése. Beépítés után a szállítási- vagy felületi sérüléseket nem ismerik el.

Szimbólumok leírása



Ne használjon ecetsavtartalmú szilikont!



Méretet (lásd a 18. oldalon)



Tartozékok (lásd a 18. oldalon)



Tisztítás

Az ajánlott tisztításhoz lásd a mellékelt brosúrát.



Vizsgajel (lásd a 20. oldalon)





Turvallisuusohjeet

-  Asennuksessa on käytettävä käsineitä puristumien ja viltojen aiheuttamien tapaturmien estämiseksi.

Asennusohjeet

- Kaluste on asennettava, huuhdeltava ja tarkastettava voimassa olevien määräysten mukaisesti!
- Ennen asennusta on tarkastettava tuotteen mahdolliset kuljetusvahingot. Asennuksen jälkeen kuljetus- ja pintavaurioita ei hyväksytä.

Merkin kuvaus



Älä käytä etikahappopitoista silikonial



Mitat (katso sivu 18)



Varaosat (katso sivu 18)



Puhdistus

Katso puhdistussuositus mukana olevasta esitteestä.



Koestusmerkki (katso sivu 20)

Säkerhetsanvisningar

-  Handskar ska bäras under monteringsarbetet så att man kan undvika kläm- och skärskadorgen werden.

Monteringsanvisningar

- Blandaren måste installeras, genomspolas och testas enligt gällande föreskrifter.
- Det måste undersökas om produkten har transportskador innan den monteras. Efter monteringen accepteras inga transport- eller ytskiktsskador.

Symbolförklaring



Använd inte silikon som innehåller ättiksyra!



Måtten (se sidan 18)



Reservdelar (se sidan 18)



Rengöring

Se den medföljande broschyren för rengöringsrekommendation



Testsgill (se sidan 20)





Saugumo technikos nurodymai

-  Apsaugai nuo užspaudimo ir įsijovavimo montavimo metu mūvėkite pirštines.

Montavimo instrukcija

- Maišytuvas privalo būti montuojamas, išleidžiamas ir patikrinamas pagal galiojančias normas!
- Prieš montuojant būtina patikrinti, ar gaminys nebuvo pažeistas transportavimo metu. Sumontavus pretenzijos dėl transportavimo ir paviršiaus pažeidimų nepriimamos.

Simbolio aprašymas



Nenaudokite silikono, kurio sudėtyje yra acto rūgšties!



Išmatavimai (žr. psl. 18)



Atsarginės dalys (žr. psl. 18)



Valymas

Valymo rekomendacijas žr. pridedamoje brošiūroje.



Bandyimo pažyma (žr. psl. 20)

Sigurnosne upute

-  Prilikom montaže se radi sprječavanja prignječnja i posjekotina moraju nositi rukavice.

Upute za montažu

- Cijevi moraju biti postavljene, isprane i testirane prema važećim normama!
- Prije montaže mora se provjeriti je li proizvod oštećen prilikom transporta. Nakon ugradnje se ne priznaju nikakve reklamacije koje se odnose na površinska i transportna oštećenja.

Opis simbola



Nemojte koristiti silikon koji sadrži octenu kiselinu!



Mjere (pogledaj stranicu 18)



Rezervni djelovi (pogledaj stranicu 18)



Čišćenje

Upute za čišćenje nalaze se u priloženoj brošiuri.



Oznaka testiranja (pogledaj stranicu 20)





⚠️ Güvenlik uyarıları

- ⚠️ Montaj esnasında ezilme ve kesilme gibi yaralanmaları önlemek için eldiven kullanılmalıdır.

Montaj açıklamaları

- Batarya geçerli normlara göre monte edilmeli, yıkanmalı ve kontrol edilmelidir!
- Montaj işleminden önce ürün nakliye hasarları yönünden kontrol edilmelidir. Montaj işleminden sonra nakliye veya yüzey hasarları için sorumluluk üstlenilmemektedir.

Simge açıklaması



Asetik asit içeren silikon kullanmayın!



Ölçüleri (Bakınız sayfa 18)



Yedek Parçalar (Bakınız sayfa 18)



Temizleme

Temizlik önerisi için birlikte verilen broşüre bakınız.



Kontrol işareti (Bakınız sayfa 20)

⚠️ Instrucțiuni de siguranță

- ⚠️ La montare utilizați mânăși pentru evitarea contuziunilor și tăierii mâinilor.

Instrucțiuni de montare

- Bateria trebuie montată, clătită și verificată conform normelor în vigoare.
- Înainte de instalare verificați, dacă produsul prezintă deteriorări de transport. După instalare garanția nu acoperă deteriorările de transport și cele de suprafață.

Descrierea simbolurilor



Nu utilizați silicon cu conținut de acid acetic!



Dimensiuni (vezi pag. 18)



Piese de schimb (vezi pag. 18)



Curățare

Pentru recomandările referitoare la curățare vezi broșura alăturată.



Certificat de testare (vezi pag. 20)





Υποδείξεις ασφαλείας

- ⚠ Για να αποφύγετε τραυματισμούς κατά τη συναρμολόγηση πρέπει να φοράτε γάντια.

Οδηγίες συναρμολόγησης

- Η κεντρική βάνα πρέπει να τοποθετηθεί, να πλυθεί και να ελεγχθεί με βάση τους ισχύοντες κανόνες υδραυλικής τέχνης!
- Πριν τη συναρμολόγηση πρέπει να εξεταστεί το προϊόν για ζημιές μεταφοράς. Μετά την εγκατάσταση δεν αναγνωρίζονται ζημιές από τη μεταφορά ή επιφανειακές ζημιές.

Περιγραφή συμβόλων



Μην χρησιμοποιείτε σιλικόνη που περιέχει οξικό οξύ!



Διαστάσεις (βλ. σελίδα 18)



Ανταλλακτικά (βλ. σελίδα 18)



Καθαρισμός

Για οδηγίες καθαρισμού βλέπε συνημμένο ενημερωτικό φυλλάδιο.



Σήμα ελέγχου (βλ. σελίδα 20)

Varnostna opozorila

- ⚠ Lors du montage, porter des gants de protection pour éviter toute blessure par écrasement ou coupure.

Navodila za montažo

- Armaturo je potrebno montirati, sprati in testirati v skladu z veljavnimi normami!
- Pred montažo je treba izdelek preveriti glede morebitnih transportnih poškodb. Po vgradnji transportne ali površinske poškodbe ne bodo več priznane.

Opis simbola



Ne smete uporabiti silikona, ki vsebuje ocetno kislino!



Mere (glejte stran 18)



Rezervni deli (glejte stran 18)



Čiščenje

Priporočilo za čiščenje glejte v priloženi brošuri.



Preskusni znak (glejte stran 20)





Ohutusjuhised

- ⚠ Kandke paigaldamisel muljumis- ja löikevigastuste vältimiseks kindaid.

Paigaldamisjuhised

- Segisti paigaldamine, loputamine ja kontroll peab toimuma vastavalt kehtivatele normidele!
- Enne paigaldamist tuleb toodet kontrollida transpordikahjustuste osas. Pärast paigaldamist ei tunnustata enam transpordi- või pinnakahjustuste kaebuseid.

Sümbolite kirjeldus



Ärge kasutage äädikhapet sisaldavat silikooni!



Mõõtude (vt lk 18)



Varuosad (vt lk 18)



Puhastamine

Puhastussoovitusi vt kaasasolevast brošüürist.



Kontrollsertifikaat (vt lk 20)

Drošības norādes

- ⚠ Montāžas laikā, lai izvairītos no saspiedumiem un iegriezumiem, nepieciešams nēsāt cimdus.

Norādījumi montāžai

- Armatūra jāuzstāda, jāizskalo un jāpārbauda atbilstoši spēkā esošajām normām!
- Pirms montāžas nepieciešams pārbaudīt, vai produktam transportēšanas laikā nav radušies bojājumi. Pēc iebūvēšanas bojājumi, kas radušies transportēšanas laikā, vai virsmas bojājumi netiek atzīti.

Simbolu nozīme



Neizmantojiet silikonu, kas satur etiķskābi!



Izmērus (skat. 18. lpp.)



Rezerves daļas (skat. 18. lpp.)



Tīrīšana

Ieteikumus tīrīšanai skatiet pievienotajā brošūrā.



Pārbaudes zīme (skat. 20. lpp.)





Sigurnosne napomene

- ⚠ Prilikom montaže se radi sprečavanja prignječenja i posekotina moraju nositi rukavice.

Instrukcije za montažu

- Armatura mora biti postavljena, isprana i testirana prema važećim normama!
- Pre montaže se mora proveriti da li je proizvod oštećen pri transportu. Nakon ugradnje se ne priznaju nikakve reklamacije koje se odnose na površinska i transportna oštećenja.

Opis simbola



Nemojte koristiti silikon koji sadrži sirćetnu kiselinu!



Mere (vidi stranu 18)



Rezervni delovi (vidi stranu 18)



Čišćenje

Preporuke za čišćenje možete naći u priloženoj brošuri.



Ispitni znak (vidi stranu 20)



Sikkerhetshenvisninger

- ⚠ Bruk hansker under montasjen for å unngå klem- og kuttskader.

Montagehenvisninger

- Armaturen skal monteres iht. gyldige standarder. De skal spyles og sjekkes!
- Før montasjen skal produktet sjekkes for transportskader. Etter monteringen aksepteres ikke noen transport- eller overflateskader.

Symbolbeskrivelse



Ikke bruk silikon som inneholder eddiksyre!



Mål (se side 18)



Serviceleder (se side 18)



Rengjøring

Se vedlagt brosjyre for rengjøringsanbefalinger.



Prøvemerket (se side 20)





Указания за безопасност

- ⚠ При монтажа трябва да се носят ръкавици, за да се избегнат наранявания поради притискане или порязване.

Указания за монтаж

- Арматурата трябва да се монтира, промие и провери в съответствие с валидните норми!
- Преди монтажа продуктът трябва да се провери за транспортни щети. След монтажа не се признават транспортни или повърхностни щети.

Описание на символите



Не използвайте силикон, съдържащ оцетна киселина!



Размери (вижте стр. 18)



Сервизни части (вижте стр. 18)



Почистване

Вижте препоръките при почистване от приложената брошура.



Контролен знак (вижте стр. 20)

Udhëzime sigurie

- ⚠ Për të evituar lëndimet e pickimeve ose të prerjeve gjatë procesit të montimit duhet që të vishni doreza.

Udhëzime për montimin

- Armatura duhet montuar, shpërlarë dhe kontrolluar në bazë të normave të vlefshme!
- Përpara montimit duhet që produkti të kontrollohet për dëmtime nga transporti. Pas instalimit nuk do të njihet asnjë dëmtim nga transporti ose dëmtim i sipërfaqes.

Përshkrimi i simbolit



Mos përdorni silikon që në përbërje ka acid acetik.



Përmasat (shih faqen 18)



Pjesë ndërrimi (shih faqen 18)



Pastrimi

Për rekomandime mbi pastrimin shikoni broshurën bashkëngjitur.



Shenja e kontrollit (shih faqen 20)





تنبيهات الأمان ⚠️

⚠️ يجب إرتداء قفازات لليد أثناء التركيب لتجنب حدوث أخطار الإنحشار أو الجروح.

تعليمات التركيب

- يجب تركيب الوصلة، وغمرها بالماء واختبارها وفقاً للمعايير السارية!
- قبل القيام بعملية التركيب، يجب فحص المنتج للتأكد من خلوه من أية تلفيات ناتجة عن النقل. بعد القيام بعملية التركيب، لن يتم الاعتراف بوجود أية تلفيات سطحية أو تلفيات ناتجة عن عملية النقل.

وصف الرمز

هام! لا تستخدم السليكون الذي يحتوي على أحماض!



أبعاد (راجع صفحة 18)



قطع الغيار (راجع صفحة 18)



التنظيف

للاطلاع على النصائح الخاصة بالتنظيف انظر الكتيب المرفق.



شهادة اختبار (راجع صفحة 20)



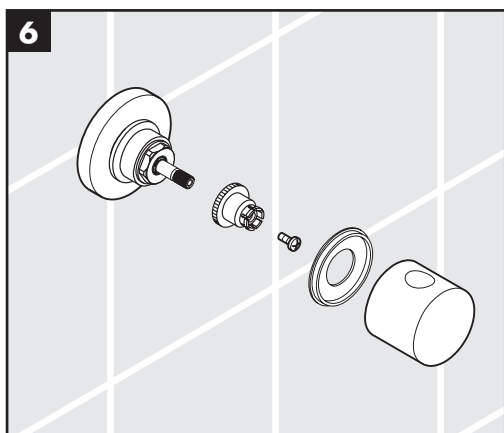
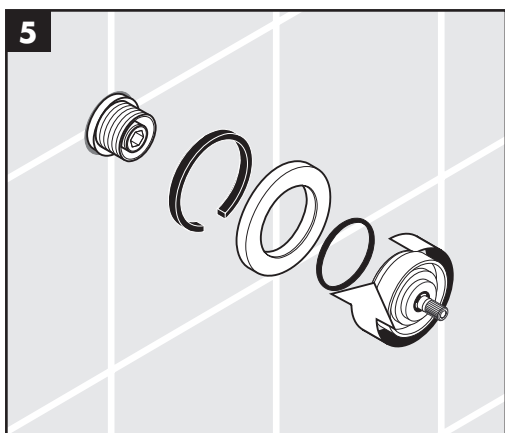
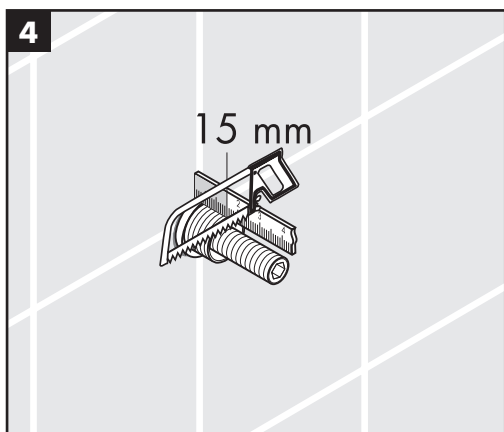
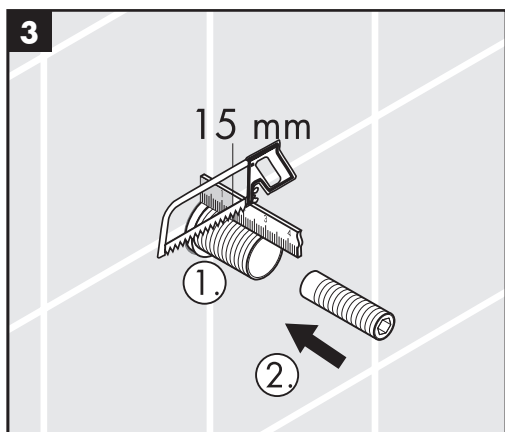
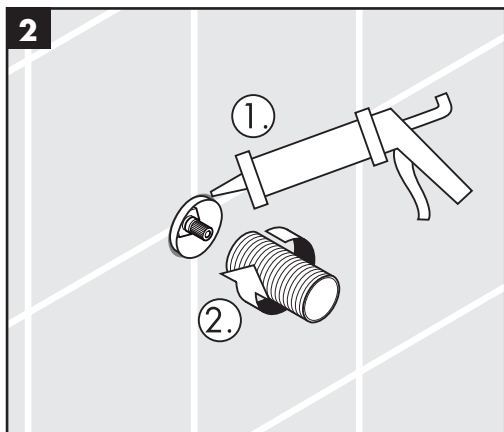
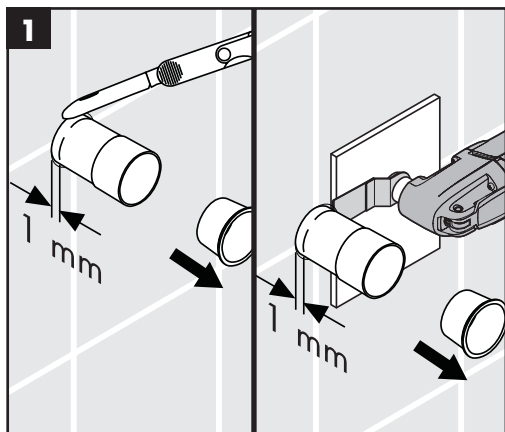

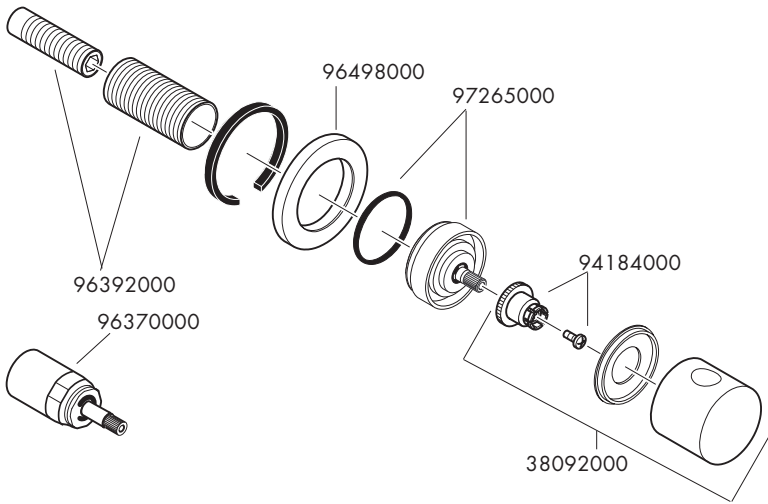
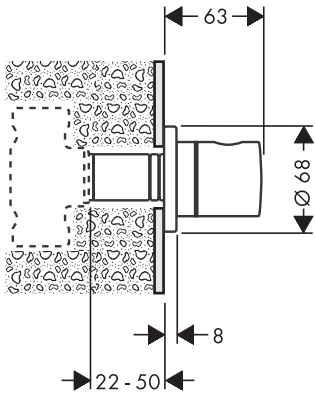





	P-IX	DVGW	SVGW	ACS	WRAS	KIWA	NF
38976000			X	X	X		

hansgrohe